

ADJUSTMENT SLIDE from metal

| MATERIAL |
|---|
| Stainless steel (18-8) 1.4310 |
| Hardness approx. 46 – 48 HRC (approx. 437 – 461 HB) |

| STANDARD DIMENSIONS* | |
|---|-----------------|
| THICKNESS mm (inch) | WIDTH mm (inch) |
| 1.0 (0.040) | 13.0 (5.118) |
| * Other widths and thicknesses available on request | |

| KEY FEATURES |
|--|
| Continuous length to individual specification |
| For the attitude of the optimal stickout out at different blade breadths of creping blades |

| SUITABLE HOLDERS |
|--|
| To fit with all standard creping blade holders |

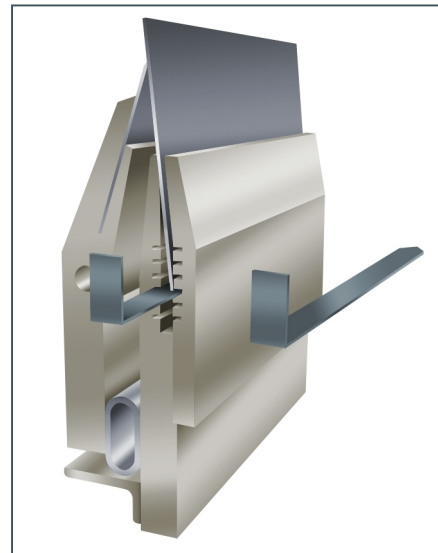

JOH. CLOUTH®
A CLOUTH GROUP MEMBER

Joh. Clouth GmbH

Johann-Clouth-Straße 1-5

D-42499 Hückeswagen

Phone: + 49 2192 853-0

E-Mail: sales@clouth-group.com